



# LIQUID RING VACUUM PUMP KS500 (V12)

**Range:** 100 to 2000 mbar  
**Capacity:** Up to 600 m<sup>3</sup>/h  
**Power:** 7,5 - 30 kW

**PROVEN  
TECHNOLOGY**

SAMSON PUMPS liquid ring vacuum pump KS500 is designed to meet the demands in continuous and rough areas and wet processes. The pump can be adapted to a specific working process and have special advantages when used in explosion proof environments.

The KS500 is as standard equipped with fully welded stainless steel rotor and shaft and mechanical shaft seals ensuring a long life and low operating costs.



## FEATURES

- Stainless steel rotor & shaft
- Mechanical shaft seals
- Wide applicability
- Few components
- Choice of materials

## BENEFITS

- Long life time cycle
- Low maintenance costs
- Cost effective performance
- Reliability and flexibility
- Low noise emission
- Vacuum and pressure



ATEX certified (zone 1)

The KS500 liquid ring vacuum pump has the latest technology incorporated. It is produced and tested under strict and continuous quality control to ensure a reliable operation.

## APPLICATION AREAS

SAMSON PUMPS KS500 liquid ring vacuum pumps are used in a wide spectrum of industrial environments such as processing, food and fishing industry, transport and off-shore.

# TECHNICAL SPECIFICATIONS



MAGNETIC POWER

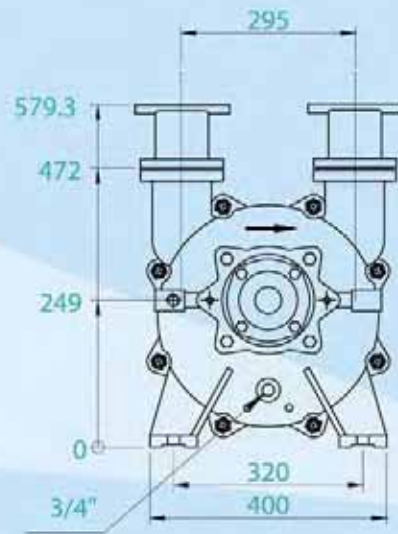
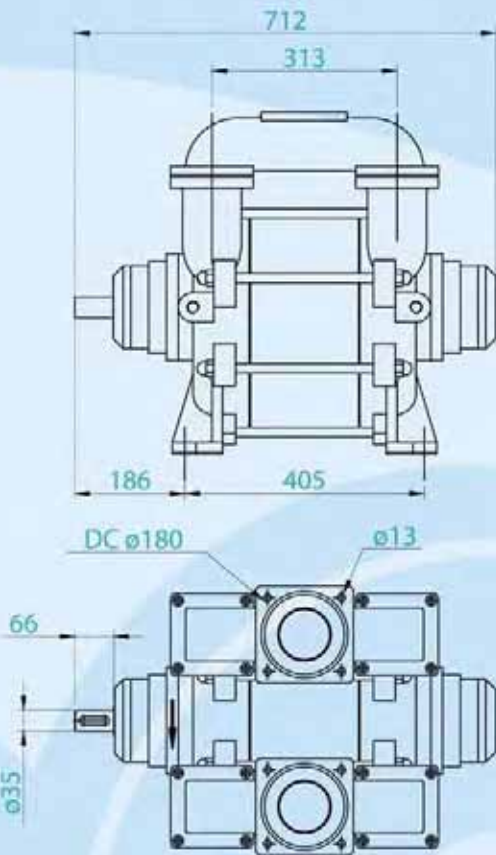

**Ex II 2 G c T4**

KS500 is ATEX certified (zone 1) for operating in potentially explosive atmospheres.

Technical data		
Weight ex. branch pipes	kg	190
Sound pressure	db(A)	78-80
Test pressure	bar,g	5
Rotation speed range	rpm	1000-1800
<sup>1)</sup> Gas temperature, max.	°C	120
<sup>2)</sup> Service liquid temperature, max.	°C	90
Bearing, greasable	-	Ball
Pump colour	RAL	5021

<sup>1)</sup> Pumps with ATEX certificate, max. temperature 80 °C

<sup>2)</sup> Pumps with ATEX certificate, max. temperature 50 °C

Material specification				
Component/material	Cast iron	St. steel	Bronze	Composite
Pump housing	EN-GJL-250 EN 1561	-	-	-
Casing	EN-GJL-250 EN 1561	WST 1.4404	-	-
Flow plates	EN-GJL-200 EN 1561	WST 1.4401	GC-CU Sn12 DIN 1705	-
Rotor	-	WST 1.4404	-	-
Shaft	-	WST 1.4418	-	-
Mechanical sealing	Carbon / NBR / stainless steel (AISI 316)			

# KS500 (V12) VACUUM PERFORMANCE



### Performance

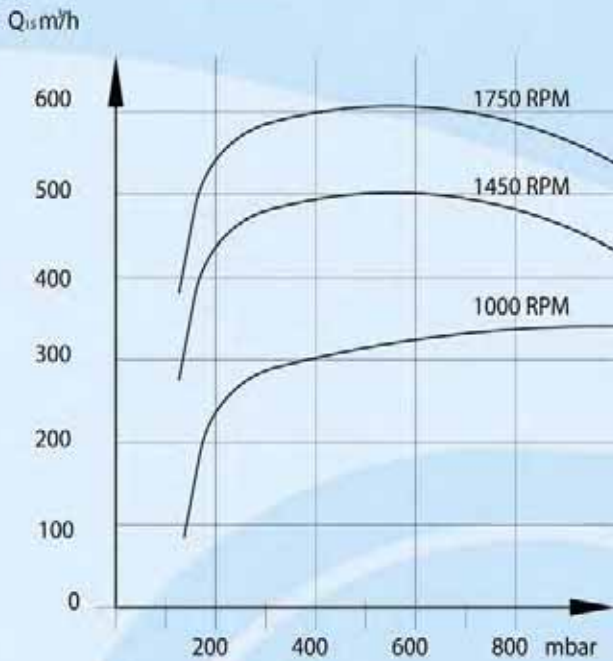

Air temperature 20°C  
 Sealing water temperature 15°C  
 Performance based on dry air at 1013 mbar  
 Tolerance +/- 10%

### Sealing water consumption

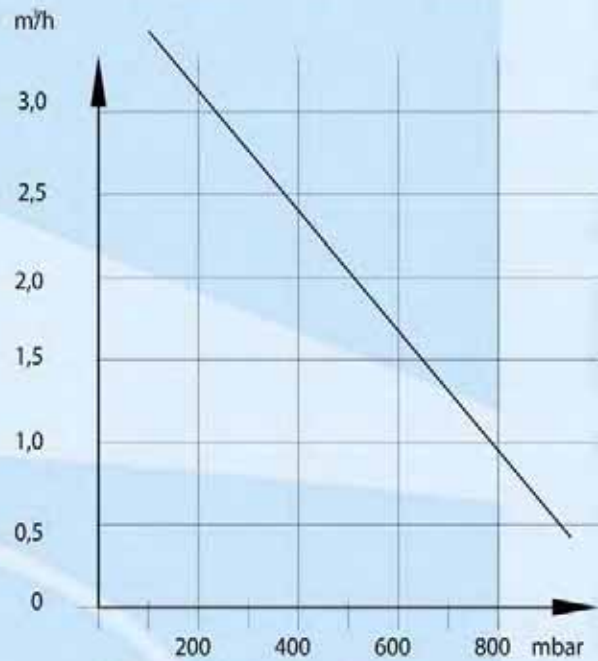

Consumption at no recovery

### Power consumption

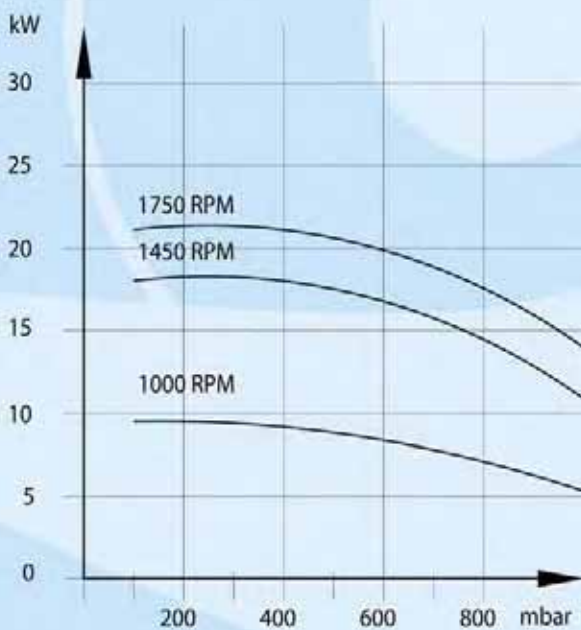

### Correction factor based on sealing liquid temperature

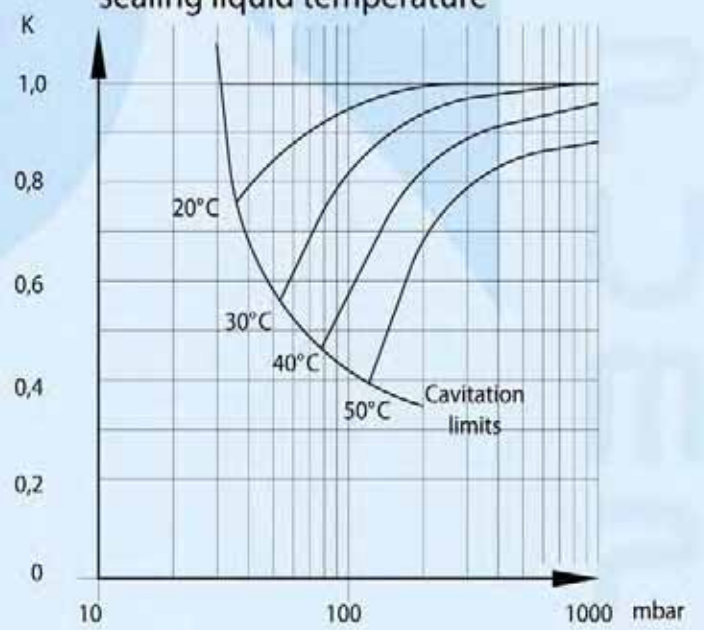

$Q = Q_s * K$   
 Pump performance at temperature of sealing liquid higher than 15°C

# KS500 PRESSURE PERFORMANCE



## Performance

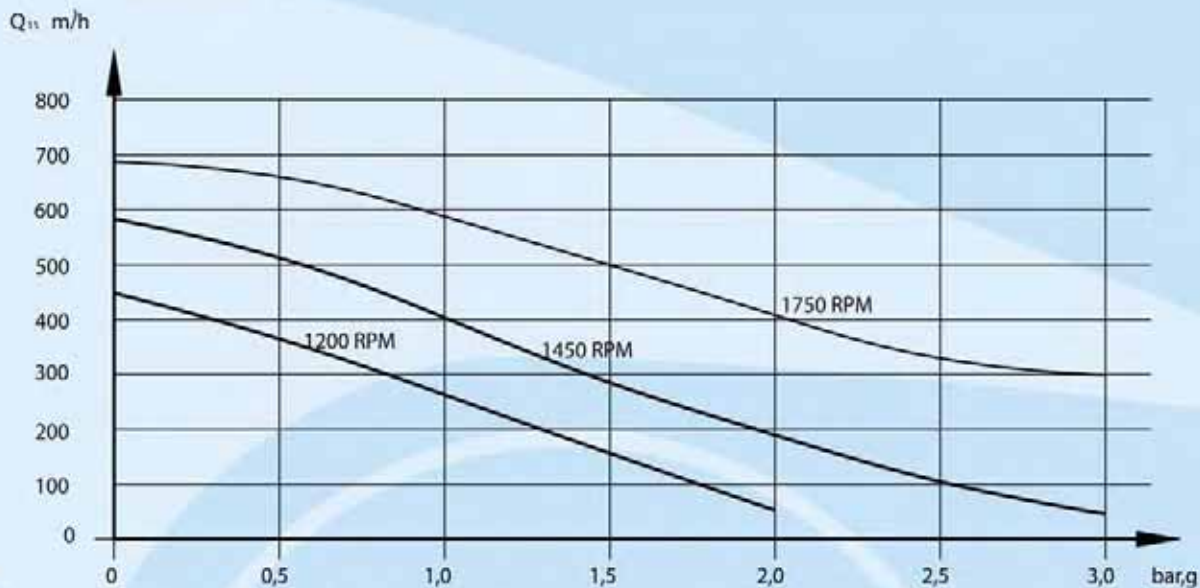

Air temperature 20°C, Sealing water temperature 15°C  
Tolerance +/- 10%  
Sealingwater flow 3 m/h

## Power consumption

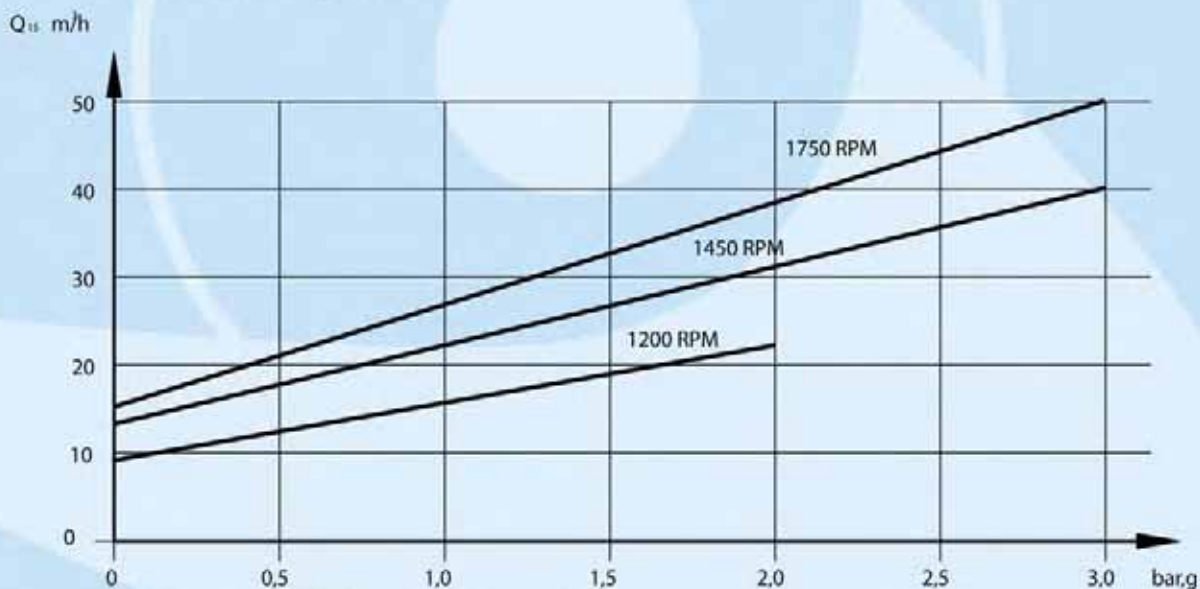

Air temperature 20°C, Sealing water temperature 15°C  
Tolerance +/- 10%  
Sealingwater flow 3 m/h